

Operating Manual

NEW KON ELECTRIC PERFORATORS

Models 10-905 • 10-905L • 10-605 • 10-705 Final 4.18.2018



MODEL: 10-905 / 10-905L



Pin Type
905



Lever Type
905L

Die-Block



MODEL: 10-605 / 10-705



605



705

Die-Block

◆ Specifications may change without prior notice for ongoing functional improvements. ◆



NEW KON INDUSTRIAL CO., LTD.

Contents

◆ Warning	3
◆ Caution	4
1. Appearance	5
2. Part names and accessories	5
3. Operating parts and descriptions	6
4. How to operate the die block	7
5. Specifications	8
6. Operating methods	9
7. Perforating operation	10-11
8. Depth adjustments	12
9. How to install and dismount the die block	13-14
10. Troubleshooting	15
11. Maintenance & Cleaning	16



PRECAUTIONS







Please be sure to read these precautions carefully before use.







Thank you for purchasing the **MODEL 10 Perforator**. For safety reasons, prior to operating this machine, please read these precautions and operating manual carefully.

Caution Notice

To use this machine correctly and in a safe manner, we added notifications to the following sections to further explain important information. Please read the following carefully.

 Caution	This mark  indicates that if instructions are not followed, serious injury and/or equipment damage may result.
--	---











 Caution	
	1. Please be sure to use the electrical plug which is attached. Do not change the plug as it could cause fire or electric shock.
	2. DON'T disassemble or modify the power cord, otherwise, injury or electrical shock may occur.
	3. If any abnormal state such as excessive heat, smoke or a bad smell occurs, IMMEDIATELY switch the main unit off and remove the power cord from the outlet. Continuing to use it as is may lead to a fire or electrical shock.
	4. Should any foreign substances (metal, liquid, etc.) get inside the unit, IMMEDIATELY switch the main unit off and remove power cord from the outlet. Continuing to use it as is may lead to fire or electrical shock. Have the unit inspected/repared by your authorized servicing dealer.
	5. DON'T insert or remove a power supply adapter with wet hands, as it may lead to an electrical shock.
	6. BE SURE to detach the power cord from the outlet by holding its plug section, NOT the cord itself, otherwise it might cause damage to the cord which could result in fire or electrical shock.

 Caution	
	1. NEVER put your hands inside the machine as it may lead to bodily injury.
	2. DON'T perforate materials other than paper as this might damage internal parts.
	3. DON'T disassemble or modify the unit, otherwise injury or electrical shock may occur.
	4. BE SURE to detach the power cord from the outlet before relocating the machine.
	5. KEEP the unit out of children's reach and do not let them operate it, otherwise injury may occur.
	6. ALWAYS detach the power cord from the outlet if the unit is not to be used for extended periods.

Caution

Safety Precautions

To ensure safe use of the machine and avoid damage to it, please be sure to observe the following precautions.

	Keep your fingers and hands away from the die block when perforating, otherwise injury may occur.
	Don't touch moving parts when perforating, otherwise injury may occur.
	Don't pull the paper out while perforating. Wait until perforation cycle is completed.
	DON'T disassemble or modify the unit as it might cause a machine malfunction, possible injury, fire or electric shock etc.
	DON'T perforate materials other than paper such as the following examples: Metals such as Iron, Copper, Aluminum, Stainless steel, etc. This may result in damage to the die block and void manufacturer warranty.
	DON'T perforate materials which adhere to the paper such as staples, paper clips, adhesive tape, etc. This may result in damage to the die block and void manufacturer warranty.
	DON'T perforate items such as wet paper, adhesion stickers, vinyl, etc. as these could cause paper chips to clog the die block.
	Perforated paper chips will accumulate in waste receptacle with frequent use of the perforator. Empty it at regular intervals (check daily). Not emptying the waste will cause paper particles to build up in the die block.
	Please be sure to remove the plug from the outlet when removing the paper waste.
	DON'T install the machine on an uneven or unstable surface as it could become susceptible to falling off.
	If you move the machine, please carry it by the bottom of the main body with both hands.

1. Appearance

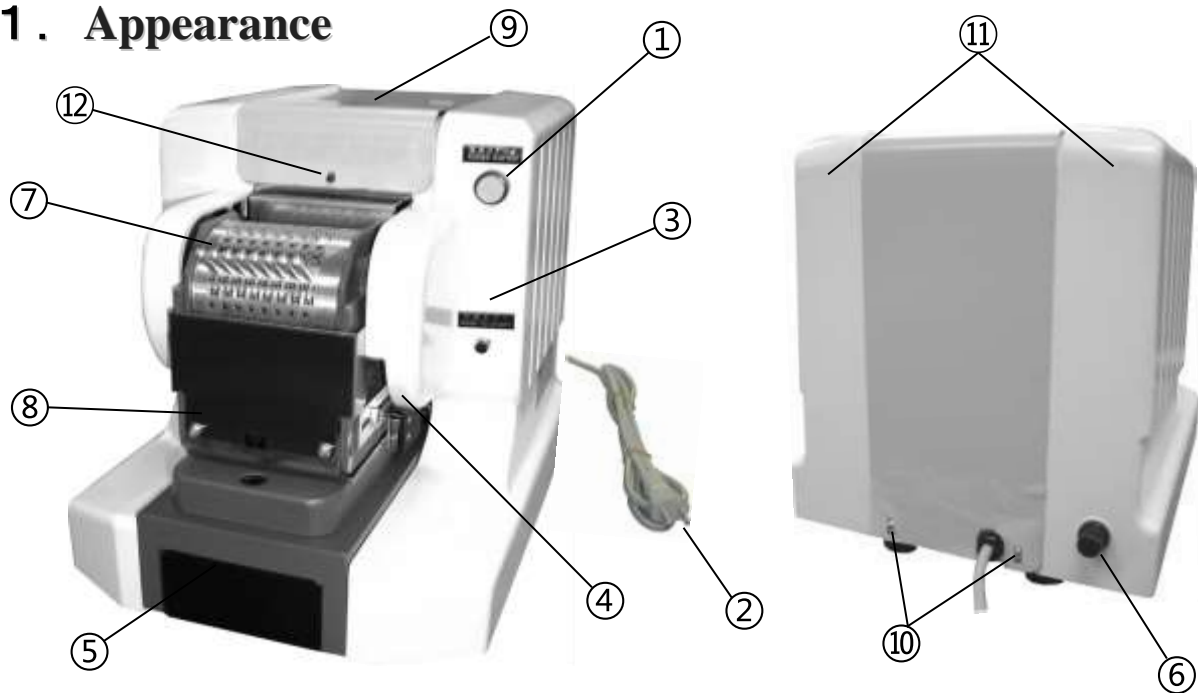

2. Part names and accessories

No.	Part Name	Description
①	Main Switch	Push button switch that turns on the power supply. (The green lamp lights up.)
②	Electric cord with plug	Plug unit into a suitable wall outlet.
③	Operating switch	Push button for manual operation if the depth switch cannot be used.
④	Micro switch	Switch for detecting when paper is inserted and the machine can punch.
⑤	Waste Drawer	Drawer for paper chip storage. Must check and empty it frequently (it is advisable to check daily).
⑥	Fuse box	Turns off the power when an excessive electric load is applied to the product.
⑦	Die block	This is the perforation die block.
⑧	Feed opening	Paper insertion area.
⑨	Top cover	A green protective cover is attached. (Please peel off before using).
⑩	Truss head screw	Screws for attaching the top cover.
⑪	Side covers	Left and Right Side Covers
⑫	Pin	This pin fits into the hole in front of the cover when installing the top cover.
Accessory bag list		1 each Operating manual 1 each spare fuse (5 amp) 1 each 6mm L shape hexagonal wrench 1 each dust cover



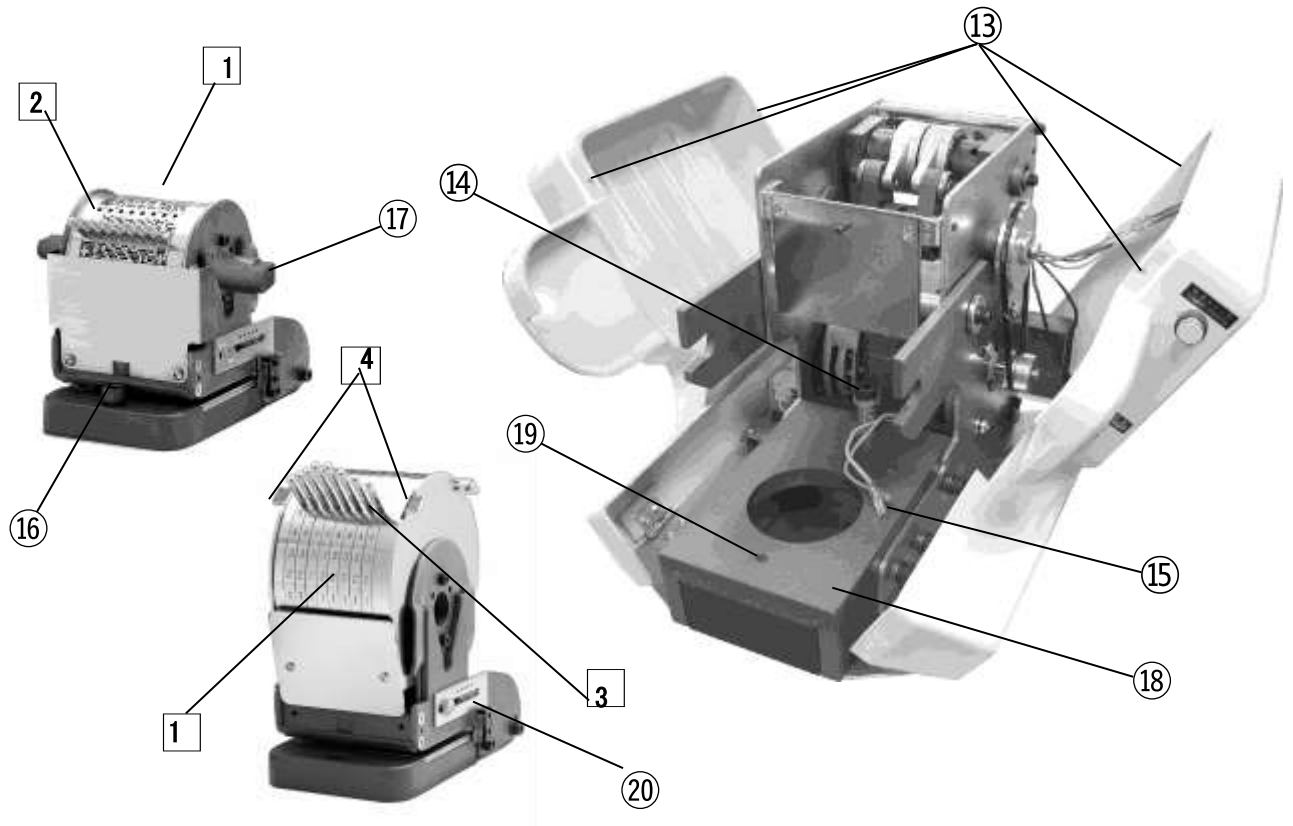





3. Operating parts and descriptions



No.	Part Name	Description
⑬	Screws for attaching the side cover	There are 4 screws; one each for front, back, left and right
⑭	Bolt for fixing the stand.	Used for setting the die block on the main body.
⑮	Micro switch connector cables	Connectors for attaching micro switch.
⑯	Cap bolt	To attach the die block to the main body.
⑰	Shaft pin	For inserting into the die block.
⑱	Alignment hole for die block	It is the screw hole for aligning the die block.
⑳	Depth gauge	Screw for adjusting the perforation depth.
❶	Wheel	Numbers, letters and/or symbols are engraved. ※Character contents, except the standard date 8 digits and 10 digits, varies depending on the customers' requests.
❷	Pin Select version	Pins that are used to select numbers, letters or logos.
❸	Lever Select version	Levers that are used to select numbers, letters or logos.
❹	Indicator	Used in Lever Select version to note correct position for proper placement of perforation.

4. How to operate the die block

- ※ There are 4 types of die blocks...905, 905L, 605 and 705.
- ※ The maximum capacity is based on 64gs/m² paper. Based upon paper thickness, number and diameter of the needles, the specifications may vary. e.g: the capacity may be less than the specified maximum.
- ※ All die blocks are equipped with a micro switch gauge for detecting the paper automatically.
The depth position can be changed by adjusting the depth gauge.
- ※ Inserting the paper: when the edge of the paper engages the micro switch, the machine will start perforating.

No.	Name	Die Block Operation	
①	 <p>905 PIN TYPE</p>	<p>■ This is a pin style die block.</p> <p>※ Remove the pin, turn the wheel until you reach the desired position letter and insert the pin. Note: please insert the pin <i>securely</i> and check that the wheel is not cycling. If the wheel pin is not inserted securely, it will cause the needles to bend and the corresponding hole in the base plate will be damaged.</p> <p>Take out the pin → turn the wheel → check that the pin is inserted securely.</p> <p>(Choose the letter-insert the pin)</p> 	
②	 <p>905L LEVER TYPE</p>	<p>■ This is a lever type die block.</p> <p>※ Move the lever up or down to choose the desired character or number</p> <p>※ The letters should match the indicator (red ▼).</p> <p>If the indicator position and lever are matched, the position is correct. Note: If the lever is not matched up with the indicator properly, it will cause the needles to bend and the corresponding hole in the base plate will be damaged.</p>	 <p>【Indicator】</p>
③	 <p>605 FIXED LETTER</p>	<p>■ This is the die block for fixed letters.</p> <p>※ Designed at the customer's request.</p> <p>※ It is a fixed die without the function for changing letters or the design.</p> <p>※ If additional design or letters are requested, another die block must be purchased.</p>	<p>(The dimension of the perforating range)</p> <p>length 20mm × width 52mm</p> 
④	 <p>705 FIXED LETTER</p>	<p>■ This is the die block for fixed letters.</p> <p>※ Designed at the customer's request.</p> <p>※ It is a fixed die without the function for changing letters or the design.</p> <p>※ If additional design or letters are requested, another die block must be purchased.</p>	<p>(The dimension of the perforating range)</p> <p>length 50mm × width 72mm</p>  <p>Note: not including 4corners(6mm×6mm)</p>

5. Specifications

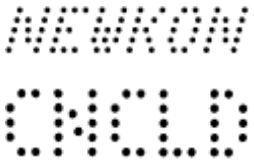
Perforator Model	Model 10 Series Electric Perforator			
Die Block Type	905	905L	605	705
Type of Selection Letter	PIN TYPE	LEVER TYPE	FIXED LETTER TYPE	
Types of Perforations	Dating or numbering • 1 st line PAID • Custom		Fixed letters or marks (including designed letters, logos, mark)	
Perforating Range	8 digits • 10 digits (needle structure : 4x6 holes)		20 x 52 mm.	50 x 72 mm.
Diameter of Needles	1.0 mm or 1.4 mm			
Perforation Examples	31+12+17 31+12+2017 123+5678 123+567890 PAID PAID 31+12+17 31+12+2017			
Perforating Ability	<i>Up to 20 sheets</i> ※ Dependent upon voltage, paper weight, needle diameter & needle configuration		5-30 sheets. ※ Dependent upon voltage, paper weight, needle diameter & needle configuration	
Perforating standard paper	Usual PPC paper (64 g/m ²)			
Perforating Time	1.5 seconds/perforation (50Hz) • 1.2 seconds /perforation (60Hz)			
Max Insertion Depth ※ from edge of paper	Maximum insertion depth: 39 mm		Maximum insertion depth: 40 mm	
Power Source	120V AC			
Power Consumption	400W			
Rated Frequency	50/60 Hz			
Current Rating	2A			
Rated Time	30 minutes			
Fuse	5A			
Dimensions (W×D×H)	240mm x 340mm x 265mm			
Weight (including die block)	23.3 kg	25.3 kg	20.5 kg	21.5 kg

6. Operating methods

■ Please read the following precautions carefully before using.

1. Be sure to check and confirm that the power supply and voltage is correct as outlined in specifications.
2. When carrying the product, please disconnect from wall and carry with two hands or put on a cart.
3. Since the perforator is very heavy, be sure to place it on a solid surface.
4. Perforating capacity is based upon PPC paper (64 g /m²).
 - a. The perforating capacity of Die Block No. 905 & No. 905L is **up to 20** sheets.
 - b. Depending upon voltage, paper weight, needle diameter & needle configuration, it is possible that the maximum of 20 sheets per perforation will not be realized.
 - c. The capacity for Model No. 605 and No. 705 will be 5-30 sheets depending upon voltage, paper weight, needle diameter & configuration.
5. Die Block Model No. 905 (Pin Type)

To change a number or character, pull out the select pin and rotate the wheel freely with your finger. When the engraved letter of each numeral, character or mark you wish to perforate is located, insert the select pin *securely* into the number or character which is on the wheel.

Please be sure that the select pin is inserted into the wheel hole securely, otherwise it may cause the needles to bend and the wheel to possibly sustain damage.
6. Die Block No.905L (Lever type)

To change a number or character on the wheel, rotate the lever up or down to the corresponding number or character you wish to perforate. Please be sure to place the lever pin in the fixed position, otherwise it may cause the it may cause the needles to bend and the wheel to possibly sustain damage. Once the lever reaches the correct fixed position, *you will feel it lock into place.*
7. Please don't perforate any material except for paper.

Examples are as follows: metals (paper clips and staples), cloth products, leather products, seals, resins, etc.
8. Please empty the paper chip storage container on a regular basis as over-accumulation can cause problems by compacting paper chips into the die block.
9. The machine is designed to start the perforation upon paper insertion. If the unit continues to activate on its' own, please disconnect and contact your local servicing dealer for assistance.
10. If paper is jammed in the die block, please disconnect and contact your local servicing dealer for assistance.
11. Please don't perforate in a previously perforated area. Change paper position for each new perforation.
12. Over time and based upon types of materials being perforated, some wear is to be expected. If the paper is not being perforated thoroughly, please contact your local servicing dealer for assistance.
13. If you will not be using the perforator for an extended period, please remove the power plug from the wall.

7. Perforating operation

■ Precautions before use

- ※ Please be sure to install the perforator on a solid surface.
- ※ Perforators are very heavy. Please take caution while moving and setting up the unit.
- ※ A protective sheet is attached to the top cover. Please remove it prior to operation.

■ Preparation for use (Pin Type: 905)

1. Insert the power plug into an AC outlet.
2. Select the date or number that you wish to perforate.
 - ※ Remove the “select” pin and rotate the wheel to the required number. Insert the “select” pin *securely*.
3. The perforation depth can be manipulated by adjusting the depth gauge.
 - ※ Please loosen the screw on the depth gauge and adjust to required position.



■ Preparation for use (Lever Type: 905L)

1. Insert the power plug into the AC outlet.
2. Select the date or number that you wish to perforate.
 - ※ Move the “lever” pin up or down to choose the desired character. Select the number and match the right and left indicator. In the desired position you can feel it lock into place.
3. The perforation depth can be manipulated by adjusting the depth gauge.
 - ※ Please loosen the screw on the depth gauge and adjust to required position.



■ Preparation for use (Fixed Die: 605/705)

1. Insert the power plug into the AC outlet.
2. These dies are for fixed characters. There are no characters to select.
3. The perforation depth can be manipulated by adjusting the depth gauge.
 - ※ Please loosen the screw on the depth gauge and adjust to required position.



■ Perforating operation (For all Model 10 Perforators)

1. Turn on the power.

※ The green power lamp will illuminate.

2. Insert the paper into the throat of the die block.

When the paper contacts the depth micro switch, the perforation process will begin.

※ If you prefer to not use the depth switch, you can use the push button switch.

3. After perforating, remove all papers before continuing.

4. After every cycle, paper chips will accumulate in the paper waste storage container.

※ Please clean the paper waste storage container daily and on a regular basis. Accumulated paper waste can clog the die if the container is not emptied regularly.

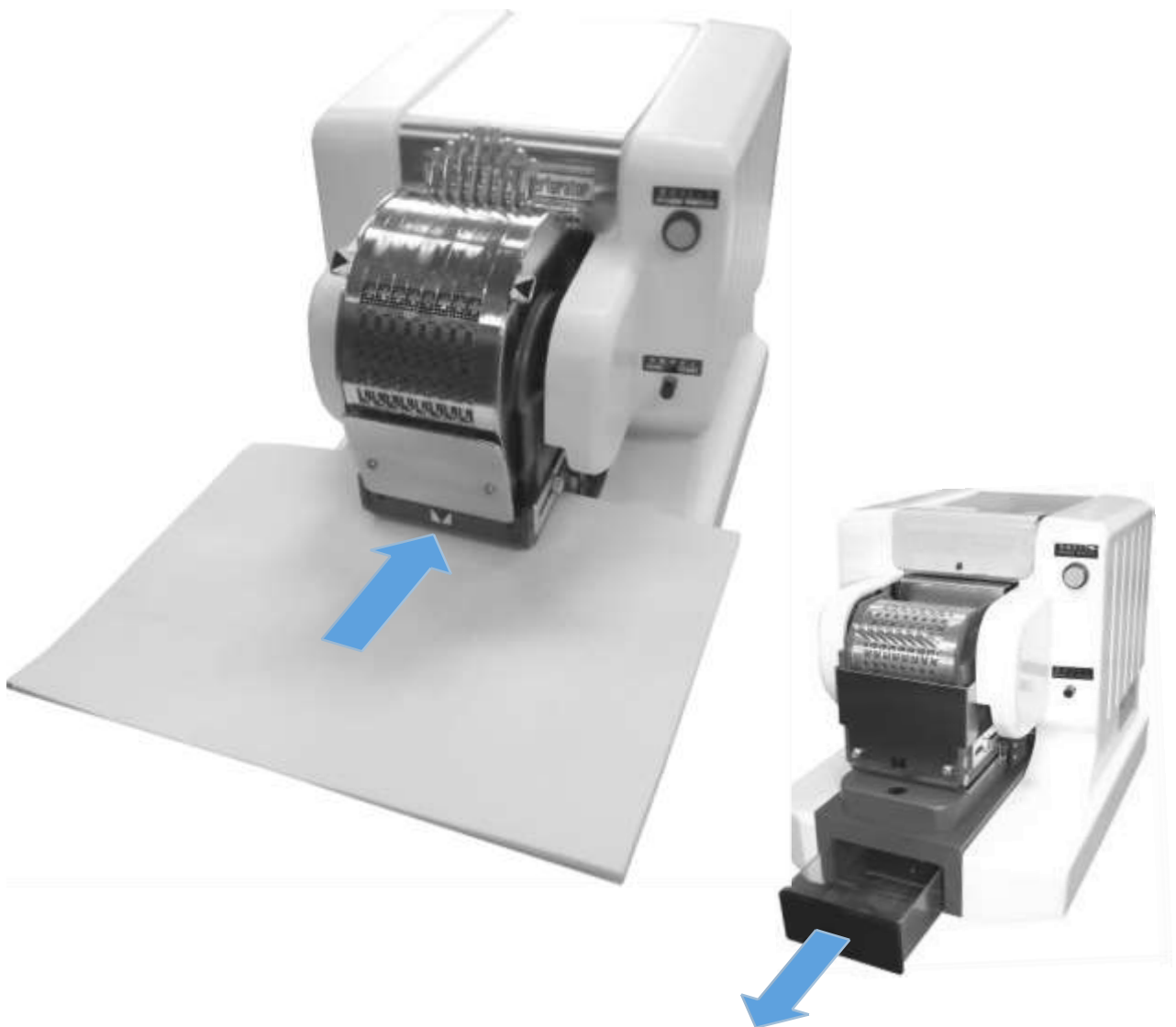

8. Depth adjustments

- There is a micro switch to auto activate the perforation cycle located on the depth gauge.
(Upon paper insertion, the machine will activate automatically.)
- The position of the micro switch is set at the point of *maximum depth* when shipped from the factory.
- If you need to change the depth, please adjust according to the following procedure.
※ The micro switch is located on the depth gauge on the right side of the die block.

Note: Please turn off the power when you adjust the depth.

Do not attempt to adjust the depth switch gauge on the left side of the die block if the power is on.

1. To adjust the depth position, please loosen the screw (20) and change the depth position by sliding the gauge either forward or backward.
2. First adjust the right side depth gauge and then adjust the left side depth gauge.
Key points of the adjustment: To check whether the position of the depth gauge is equal on both the left and right side, insert one piece of paper and check the squareness of the paper.
3. After the adjustments are made, please turn on the power and make a perforating test. Check the positioning of the perforation and make final adjustments as necessary.

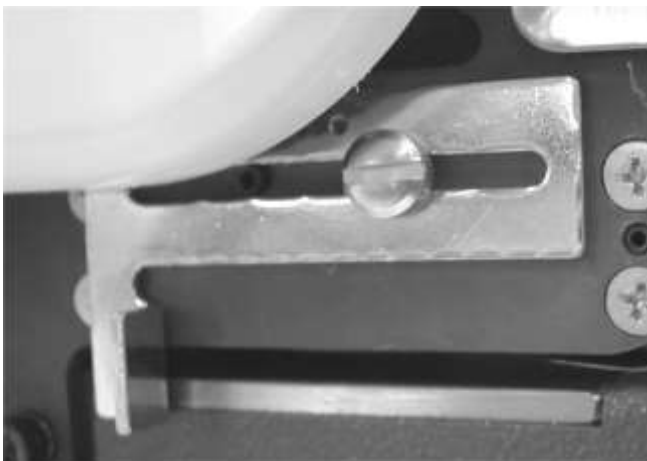

Left depth gauge

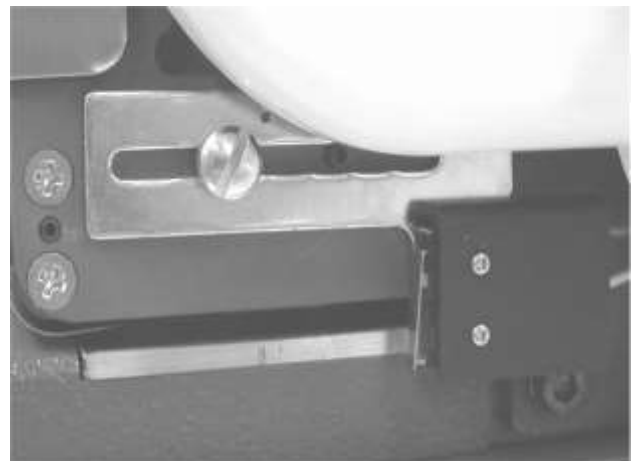

Right depth gauge

9. How to remove and install a die block

■ Following is the procedure to remove and install a die block.

※ Note: Be sure to turn off the power and unplug the power plug from the outlet before attempting repairs.

■ TOOLS NEEDED: Phillips screwdriver.



Allen wrench (located in the accessory bag).



1. Remove the 2 top cover screws (10) at the rear of the main unit.
2. There is a fitting pin (12) on the front of the top cover (9). Please pull it up and remove the top cover.
3. Remove the 2 front and 2 back side cover screws (13) which are for attaching the side cover (11)
The side covers can now be spread open (note: please do not force the side covers into the “open” position).
4. Remove the die block fixing screw (16) with the enclosed Allen wrench
5. Disconnect the harness from the depth gauge assembly.
6. Slowly pull on the die block and remove it.
7. Pull the shaft pin (17) out of the die block.
8. Prepare the new die block for replacement.
9. Insert the shaft pin (17) into the new die block.
10. Place the die block on the die base and connect the depth gauge switch.
11. Pull up the shaft pin (17), insert it into the arm, push the die block all the way in.
12. Attach the die block with the screw (16) and *firmly tighten*.
13. Close the side covers (11) and attach with the front and back screws (13).
14. Insert the fitting pin (12) into the hole in the front of the top cover (9) and attach the top cover (9).
15. Tighten the top cover screws and attach the top cover firmly.
16. The die block replacement is now completed.

Remove the 2 screws on the back of the top cover.
Lift up the top cover and remove it.

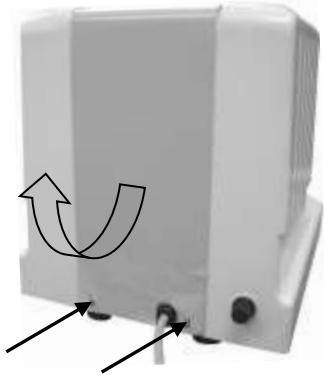

There is a fitting pin on the front of the top cover



Remove the 4 screws from the side covers.
Spread the side covers to the left and right sides.

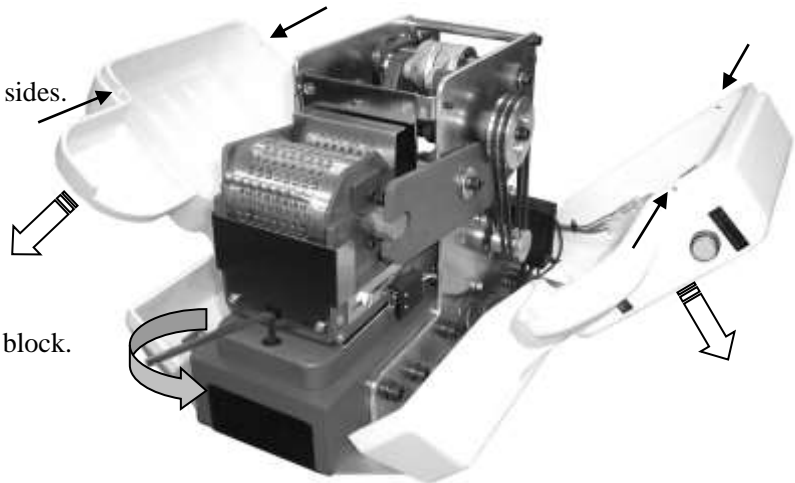

Remove the screw which is attached to die block.

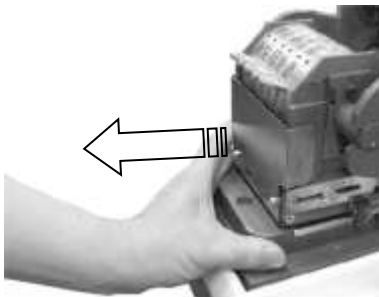

Pull the die block out partially.



Remove the connector of the depth switch to
withdraw the die block.

Pull the shaft pin out.

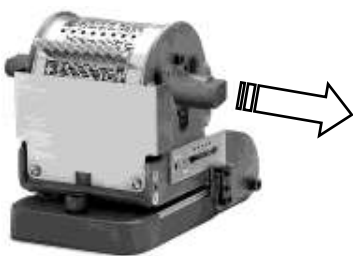

10. Troubleshooting.....

No.	Malfunction Description	Inspection and potential solutions
1	<p>A. No power (the power lamp is not lit)</p> <p>B. Cannot perforate</p>	<p>A1: Is the power plug inserted into the AC outlet? Please insert the power plug into the AC outlet.</p> <p>A2: Is the fuse blown? Please inspect and replace with the spare fuse.</p> <p>B1: Is the paper touching the depth switch? If the paper is not touching the depth switch, the micro switch cannot activate. Please adjust the depth gauge.</p> <p>In this case, please activate the push button manually.</p>
2	<p>A. The perforated holes are not normal.</p> <p>B. Cannot perforate the holes according to selection.</p> <p>C. Perforate extra holes.</p> <p>D. Some holes cannot perforate (in case of fixed letters)</p>	<p>A1: The tip of needle or the hole of die plate is worn out. ※ Please replace the needles or the die plate</p> <p>B1: The needles are bent or the needles are damaged. Contact your local authorized servicing dealer.</p> <p>C1: Pin Style: the selector pins were not inserted securely. Lever Style: the lever is not positioned securely. ※ Select the number or letters correctly and check if the position is accurate.</p> <p>D1: The needles are possibly bent or the needles are damaged. Contact your local authorized servicing dealer.</p>
3	<p>A. Strange sound occurred</p> <p>B. Working continuously</p> <p>C. The machine has power but is not perforating</p> <p>D. Cannot remove the paper chip storage container to empty it.</p>	<p>A1: The tip of needle or the hole in the die plate is worn out. ※ Please replace the needles and/or the die plate</p> <p>A2: Lack of maintenance and lubrication. ※ Please lubricate all moving parts.</p> <p>B: The needles are bent or the needles are damaged. ※ Contact your local authorized servicing dealer.</p> <p>C: The belt is slipping. ※ Contact your local authorized servicing dealer.</p> <p>D: The paper chip waste container is overloaded. ※ Don't forcibly remove the container. Contact your local authorized servicing dealer.</p>

※ If you experience problems/symptoms other than outlined above, please turn off the power and remove the power plug from the AC outlet. Contact your local authorized servicing dealer.

※ If you went through the troubleshooting procedures listed above, and the symptoms remain, turn off the power and remove the power plug from the AC outlet. Contact your local authorized servicing dealer.

11. Cleaning and Maintenance

1. Please check & empty the paper waste storage container prior to/during operation or on a regular schedule.
2. If you would like to clean the cover of the product, please wipe it with a clean, soft dry cloth.

Lubricating points

※ Periodically lubricate parts with a light machine oil where indicated by the arrows

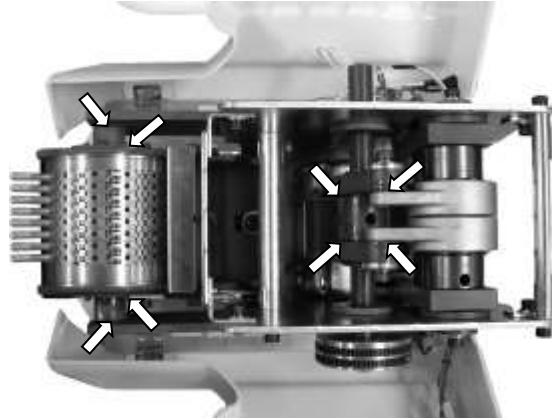
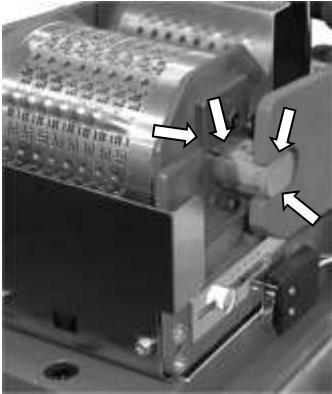

※ Lubrication on both sides (left and right)

DIE BLOCK SCHEDULED MAINTENANCE& USAGE RECOMMENDATIONS

1. Lubricate parts indicated by the arrows periodically (recommend once per month during heavy use periods)
2. When selecting numbers or characters, please be sure to position the desired character on the correct wheel stop/alignment position before activating the machine.
Model 905 Pin Selector Die...when selecting the desired number or character, please be sure to insert the wheel selector pin into the die block ***firmly and in proper alignment***.
Model 905L Lever Selector Die...when selecting the desired number or character, please be sure that the position is in the ***correct wheel stop/alignment position***.
If the selected number or character is not in the correct position and the machine is activated, it is possible that the needles, wheels and/or die plate ***may sustain damage***.
3. According to the frequency of use, please clean paper waste materials from the die block periodically.
4. Please check the paper waste storage regularly and discard the paper chips before the container is full.
If you use the machine continuously and do not discard the paper waste regularly, it will be difficult to remove the paper waste storage container. If waste storage clearance is neglected, it may also cause the die block needles to sustain damage.

PARTS LIST

1. V-Belt . . . replace as needed due to long term usage or if the perforator has been frequently overloaded.
2. Needles . . . replace as needed due to long term usage or not following correct procedures as noted above.
3. Die plate . . replace as needed due to long term usage or not following correct procedures as noted above.
4. Wheels . . . replace as needed due to long term usage or misalignment of selected numbers or characters.

J.Snell & Co., Inc.
156 Mendell Street
San Francisco, CA 94124

415.206.7700
www.perforatorsplus.com
[*info@perforatorsplus.com*](mailto:info@perforatorsplus.com)

ADG04182018 V3.

